



Dunnville Drinking Water System 2020 Annual Water Quality Report

January 1, 2020 – December 31, 2020

TABLE OF CONTENTS

QUALITY MANAGEMENT SYSTEM **2**

HALDIMAND COUNTY QUALITY MANAGEMENT SYSTEM SUMMARY

DRINKING WATER SYSTEM **4**

DUNNVILLE DRINKING WATER SYSTEM MAP
DUNNVILLE DRINKING WATER SYSTEM OVERVIEW
EXPENDITURE INFORMATION
MULTI-BARRIER APPROACH

WATER SAMPLING **8**

MICROBIOLOGICAL
OPERATIONAL
LEAD
ORGANIC

WATER USE **12**

RAW WATER
POTABLE WATER

REGULATORY COMPLIANCE **14**

ADVERSE WATER QUALITY INCIDENTS
SAFE DRINKING WATER ACT APPROVAL
ANNUAL DRINKING WATER INSPECTION

REPORT AVAILABILITY **16**

APPENDICES **17**

INORGANIC AND ORGANIC SAMPLE RESULTS
MICROCYSTIN SAMPLE RESULTS
HARDNESS SAMPLE RESULTS

Quality Management System Policy

The purpose of The Corporation of Haldimand County's Quality Management System policies are to:

- Ensure our drinking water systems comply with all current legislation and regulatory requirements for the safe supply of drinking water;
- Ensure financial support is provided to maintain infrastructure integrity to allow safe and consistent delivery of drinking water to our water customers;
- Commit to review and update our Operational Plans as regulated by the Drinking Water Quality Management Standard in order to continually improve our Quality Management System and to communicate the results with our water customers.



Haldimand
County

Haldimand County Quality Management System Summary

Haldimand County's Quality Management System (QMS) is legislated under the Drinking Water Quality Management Standard (DWQMS) through the Safe Drinking Water Act. To maintain operating authority accreditation, the Ministry of the Environment, Conservation and Parks (MECP) mandate tasks that must be completed annually. These activities include:

- Conducting an internal audit of the Quality Management System.
- Conducting a Management Review meeting.
- Participating in an external audit conducted by a third party Accreditation Body
- Updating the Quality Management System Operational Plan.
- Updating Council of the status of the County's Quality Management System.

The QMS Operational Plan was reviewed and updated in 2020, with a focus on Document and Records Control (Element 5) and incorporating organizational changes within the County.

Internal audits were completed with support from Water and Wastewater Operations staff. An audit report was generated that identified two minor non-conformances and opportunities for improvement.

Haldimand County must receive accreditation annually to operate the water distribution systems. Through a qualified third party auditor, the County must demonstrate that its QMS meets the requirements of the DWQMS. SAI Global conducted an external audit on October 23, 2020. The County did not receive any non-conformances and will discuss identified opportunities for improvement and develop an implementation strategy.

Staff are required to conduct an annual Management Review meeting to evaluate the effectiveness of the QMS. Deficiencies and opportunities for improvement are identified and action items are developed to ensure follow-up. The County held their management review meeting on November 10, 2020.

All requirements were achieved in 2020 and SAI Global have issued an accreditation certificate to Haldimand County, which allows us to continue to operate the water distribution systems.

As part of the agreement with the County and through the regulations, Ontario Clean Water Agency (OCWA) must obtain accreditation to operate the water treatment facilities on behalf of the County. On September 25, 2020, OCWA obtained limited scope transitional accreditation.

DUNNVILLE DRINKING WATER SYSTEM

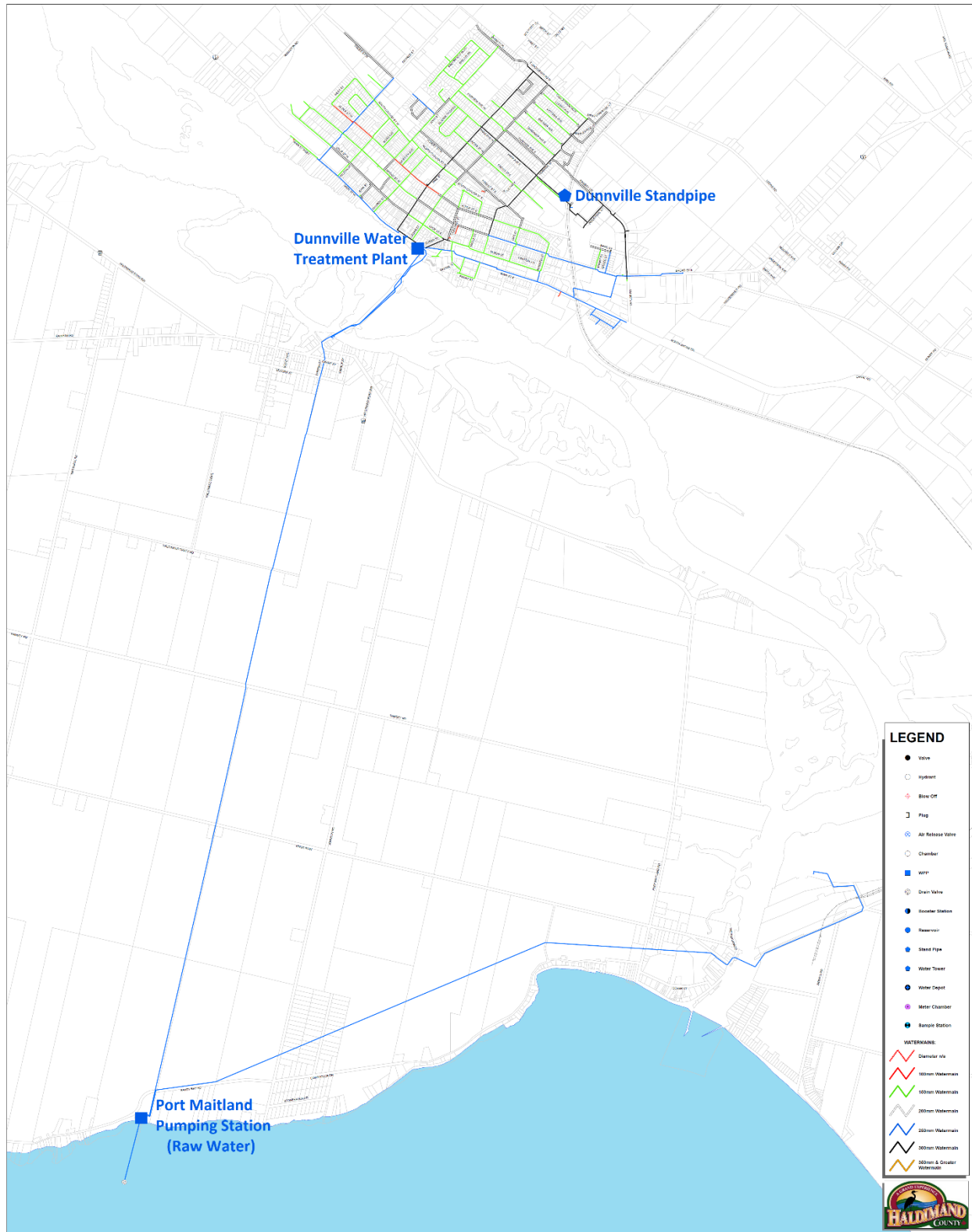

Dunnville Drinking Water System Overview

The Dunnville Drinking Water System's primary raw water source is Lake Erie. Raw water is drawn into the Port Maitland Low Lift Pumping Station where it can be pre-chlorinated with sodium hypochlorite for zebra mussel control. Raw water is then pumped through approximately ten kilometres of raw water transmission watermain to the Dunnville Water Treatment Plant. Raw water is also supplied to industrial users in Port Maitland.

There is also a raw water intake located in the Grand River. This raw water source has not been used to supply the treatment plant since the early 2000's, however it is available for use in an emergency situation.

The Dunnville Water Treatment Plant is a conventional water treatment plant with a rated capacity of 14,500 m³/day. A coagulant (Aluminum Sulphate was used in 2020) is injected into raw water and undergoes flash mixing. Water then flows through a series of flocculation and sedimentation tanks to five dual media filters containing sand and granular activated carbon. Following filtration, the water is disinfected with sodium hypochlorite and stored in two reservoirs. High lift pumps deliver potable water to the Dunnville Water Distribution System.

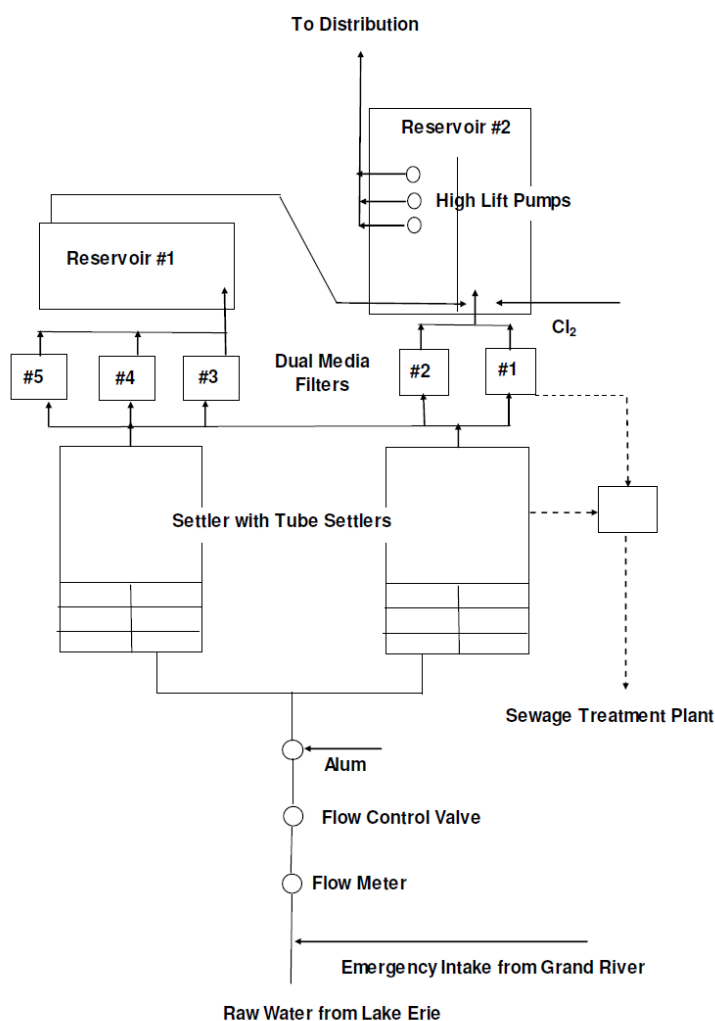

Figure 1: Dunnville Water Treatment Plant Schematic

The water distribution system utilizes a standpipe for storage and to maintain water pressure. A bulk water depot provides potable water to rural residents and bulk water haulers.

The distribution system infrastructure services approximately 5,759 people (2016 Census).

Veolia Water was contracted to operate and maintain the raw water transmission mains, low lift pumping station, water treatment plant, and the standpipe until September 30, 2020. As of October 1, 2020, the County entered into a contract with Ontario Clean Water Agency to operate and maintain the water treatment facilities. Haldimand County operates and maintains the distribution system and the bulk water depot.

Expenditure Information

Haldimand County and its contract operators are diligent in prioritizing projects on an annual basis to eliminate unnecessary expenditures. Using the best available information at the time of this report, expenses incurred in the Dunnville Drinking Water System for 2020 are identified in Table 1. All drinking water expenditure information is not included in this report.

Table 1: Dunnville Drinking Water System 2020 Expenditures

Dunnville Drinking Water System:	
Dunnville WTP Filters 1 and 2 Air Scour and Underdrains	
Dunnville WTP Backwash Filter Room Rehabilitation	
Dunnville WTP Upgrades	
Port Maitland Transmission Main Valve Chamber Repair	
Port Maitland Genset Replacement	
Port Maitland Low Lift Facility Capital Repairs	
	Total Cost: \$4,098,184

Multi-Barrier Approach

Through the Walkerton Inquiry, Justice O'Connor recommended that drinking water is best protected by taking an approach that uses multiple barriers to prevent contamination from affecting our drinking water. The multi-barrier approach addresses potential threats by ensuring barriers are in place to either eliminate or minimize their impact. This holistic approach recognizes that each barrier may not be able to completely remove a contaminant, but by working together the barriers provide a high-level of protection. Typical barriers include:

- **Source Protection**
 - **Source Protection Plans**
- **Treatment**
 - **Treatment and Disinfection Goals**
- **Distribution System**
 - **Chlorine Residual Maintenance**
- **Monitoring**
 - **Sampling Programs**
- **Emergency Preparedness**
 - **Emergency Plans**



Haldimand County has adopted the multi-barrier approach in ensuring safe, reliable drinking water. *Figure 2* shows how administration, design, maintenance, and operation work together to establish and maintain multi-barrier protection (US EPA, 1998).

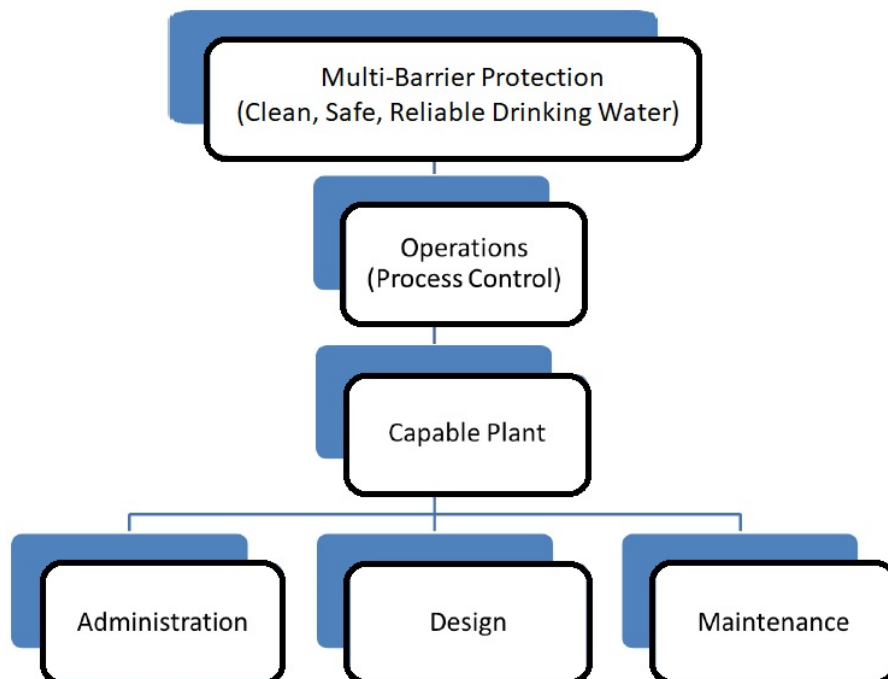

Figure 2: Responsibilities for Clean, Safe and Reliable Drinking Water

A description of the responsibilities in each area is summarized as follows:

- **Administration:** The administrators or managers of a water treatment system are responsible for providing the resources (budget and staff) and policies (hours of staffing, reporting requirements, training and certification requirements, etc.). Funding may also need to be justified and obtained if the design of a system is inadequate or major upgrades are required. Managers establish and maintain emergency response plans and communication procedures to ensure prompt response to unsafe drinking water.
- **Design:** The designer's responsibility is to provide the physical infrastructure (pipes, valves, tanks, meters, etc.) capable of reliably producing and distributing the quality and quantity of water required. The design must provide adequate flexibility and controllability to enable the operator to make appropriate adjustments.
- **Maintenance:** The system must be maintained in good working order with the key equipment functional at all times. Should a key piece of equipment break down then it should be repaired in a timely manner.
- **Operations:** Once a capable system is in place, then it is the operator's responsibility to deliver safe drinking water through monitoring, testing and process control (for example by changing the setting on the dosing pumps). Operators are also responsible for maintaining records (log books, data forms, etc.), which aid in troubleshooting and design of upgrades. A further, and commonly unrecognized responsibility of the operator is to communicate the needs of the facility to administrators for possible action.

WATER SAMPLING

To comply with drinking water legislation, drinking water systems are required to monitor their water quality. Haldimand County has committed to providing safe, reliable drinking water and is diligent in ensuring that sampling and monitoring programs effectively characterize water quality. All samples are taken by certified operators and tests performed by accredited, licensed laboratories.

Microbiological Sampling

Microbial quality is one of the primary indicators for the safety of a drinking water supply. Of all contaminants in drinking water, human and/or animal feces present the greatest danger to public health. Pathogenic or disease causing micro-organisms (including certain protozoa, bacteria or viruses) may be found in untreated water supplies. Bacteriological monitoring and testing is a way to detect and control pathogenic bacteria in treated drinking water supplies. Heterotrophic Plate Count (HPC) samples are monitored to identify potential changes in water quality and are not used as an indicator of adverse human health effects. Table 2 provides a summary of microbiological sampling completed in the Dunnville Drinking Water System during 2020.

Table 2: 2020 Dunnville Drinking Water System Microbiological Sampling

	Number of Samples	Range of E.coli Results (cfu/100ml)	Range of Total Coliform Results (cfu/100ml)	Number of HPC Samples	Range of HPC Results (cfu/ml)	Number of Background Samples	Range of Background Results (cfu/ml)
Raw – Lake Erie	52	0 – 1,100	2– 2,000,000	N/A	N/A	N/A	N/A
Raw at WTP	52	0 - 200	0 – 38,000	N/A	N/A	N/A	N/A
Raw – Grand River	52	2 – 1,300	6 – 137,000	N/A	N/A	N/A	N/A
Treated	156	0	0 - 1	156	0 - 20	123	0
Distribution System	260	0	0	104	0 - <10	249	0 - 30

*Note: At a minimum, 25% of all drinking water samples must be analyzed for HPC.

Operational Sampling

Operational sampling and monitoring is important in maintaining the integrity of each barrier in the multi-barrier approach. Schedule 7 and 8 of Ontario Regulation 170/03 specify requirements for operational checks that municipalities must follow. Table 3 provides a summary of operational samples taken for the drinking water system. Regulatory requirements were consistently achieved for filtered water turbidity and efforts continue to consistently achieve recommended settled and filter targets. Disinfection regulatory requirements and operational targets were consistently achieved in 2020.

Table 3: 2020 Dunnville Drinking Water System Operational Sampling

	Number of Grab Samples	Range of Results	Regulatory Requirement	Recommended Target
Raw Turbidity	8760	2.39 - 269	N/A	N/A
Settled Turbidity	8760	0 – 36.1	N/A	2.00 NTU
Filter Turbidity	8760	0.043 - 0.243	≤ 0.30 in 95% of all monthly readings	0.10 NTU
Treated Turbidity	8760	0.01 - 0.43	N/A	≤ 5.00 NTU
Free Chlorine High Lift	8760	0.75 – 1.51	≥ 0.05 mg/L	≥ 0.20 mg/L
Free Chlorine Distribution System	416	0.28 - 1.26	≥ 0.05 mg/L	≥ 0.20 mg/L

*Note: 8760 is used for continuous monitoring (24 samples per day * 365 days/year)

As result of public inquiries, a quarterly treated water hardness sampling program was initiated.

The term hardness was originally applied to waters that were hard to wash in, referring to the soap wasting properties of hard water. Hardness prevents soap from lathering by causing the development of an insoluble curdy precipitate in the water; hardness typically causes the buildup of hardness scale (such as seen in cooking pans). Dissolved calcium and magnesium salts are primarily responsible for most scaling in pipes and water heaters and can cause numerous problems in laundry, kitchen, and bath. Hardness is usually expressed in grains per gallon (or ppm) as calcium carbonate equivalent.

The degree of hardness standard as established by the American Society of Agricultural Engineers (S-339) and the Water Quality Association (WQA) is shown in the following table:

Table 4: Standard Degree of Hardness

Degree of Hardness	Grains per Gallon (gpg)	Ppm (mg/L)
Soft	< 1.0	< 17.0
Slightly Hard	1.0 – 3.5	17 - 60
Moderately Hard	3.5 – 7.0	60 - 120
Hard	7.0 – 10.5	120 - 180
Very Hard	> 10.5	> 180

The sample results in Table 5 indicate that the average value for Dunnville is considered to have hard water as taken from the Degree of Hardness Table above.

Table 5: 2020 Dunnville Drinking Water System Hardness Sampling

Parameter	Sample Date	Dunnville
Total Hardness (mg/L as CaCO₃)	February 25, 2020	120
	June 9, 2020	128
	August 25, 2020	119
	November 17, 2020	128
	2020 Average ----->	124

Lead Sampling

The community lead testing program is a requirement of O. Reg. 170/03 under the Safe Drinking Water Act, 2002. Haldimand County is exempt from sampling private residences due to having less than 10% of plumbing sample locations exceed the standard for two consecutive periods of reduced sampling. Annual pH and alkalinity samples are taken, as well as distribution system lead samples, every three years. There are no regulatory limits for alkalinity and pH, however Haldimand County sample results are within the operational guidelines provided by the MECP. A summary of 2020 sampling has been provided in Table 6.

Table 6: 2020 Dunnville Drinking Water System Lead Sampling

Location Type	Number of Samples	Range of Results (min) – (max)	Number of Exceedances
Plumbing - Lead	N/A	N/A	N/A
Distribution - Lead	3	0.10 – 0.41 µg/L	0
Distribution - pH	3	7.35 - 7.38	N/A
Distribution - Alkalinity	3	83 – 85 mg/L	N/A

Organic Sampling

To protect drinking water from pathogens, a disinfectant (usually chlorine) is added to the drinking water. Disinfectants can react with naturally-occurring materials in the water to form disinfection byproducts (DBP), which may pose health risks.



A challenge for water systems is balancing pathogen control and disinfection byproduct formation. It is important to provide protection from pathogens while minimizing health risks from disinfection byproducts. More information on each byproduct is summarized in Table 7.

Haldimand County sample for haloacetic acids (HAA) and trihalomethanes (THM) at the water treatment plant and in the distribution system where there is an elevated potential for the formation of these byproducts. Although a treatment sample is not required by regulation, the sample is used to monitor byproduct formation within the drinking water system.

Table 7: Disinfection Byproduct Information

Disinfection Byproduct	How it is formed?	Health Effects
Trihalomethanes	Trihalomethanes occur when naturally-occurring organic and inorganic materials in the water react with the disinfectants, chlorine and chloramine.	Some people who drink water containing total trihalomethanes in excess of the MCL over many years could experience liver, kidney, or central nervous system problems and an increased risk of cancer.
Haloacetic Acids	Haloacetic acids occur when naturally-occurring organic and inorganic materials in the water react with the disinfectants, chlorine and chloramine.	Some people who drink water containing haloacetic acids in excess of the MCL over many years may have an increased risk of getting cancer.

Regulatory reporting is based on a running annual average of quarterly sample results. The calculated THM and HAA averages were below the maximum allowable concentrations (MAC) permitted by the MECP. Table 8 provides a summary of 2020 disinfection byproduct sampling.

Table 8: 2020 Dunnville Drinking Water System DBP Sampling

Parameter	Sample Date	Sample Results (ug/L)	Annual Average (ug/L)	Regulatory MAC (ug/L)	Exceedance
Haloacetic Acids Dunnville WTP	February 3, 2020	5.0	5.1	80	No
	May 4, 2020	4.4			
	August 4, 2020	5.8			
	November 2, 2020	5.3			
Haloacetic Acids Dunnville Distribution	February 20, 2020	< 5.3	5.4	80	No
	May 12, 2020	< 5.3			
	August 4, 2020	5.5			
	November 3, 2020	< 5.3			
Trihalomethanes Dunnville WTP	February 3, 2020	9.0	13.6	100	No
	May 4, 2020	13.2			
	August 4, 2020	19.3			
	November 2, 2020	13.0			
Trihalomethanes Dunnville Distribution	February 20, 2020	14.0	27.8	100	No
	May 12, 2020	24.0			
	August 4, 2020	44.0			
	November 3, 2020	29.0			

Additional sample results for organic and inorganic parameters can be found in the appendices.

WATER USE

Raw Water

The Dunnville Drinking Water System’s raw water source is Lake Erie. A Permit to Take Water (PTTW) specifies the maximum volume of raw water that can be taken from the water source and conveys MECP site-specific regulatory requirements. When comparing the 2020 maximum raw water flow and the permit limits (*Figure 3*), 79.9% of Haldimand County’s raw water allotment was available for use. The Grand River water supply was used in 2020 to conduct a treatability trial, however was not sent to the distribution system.

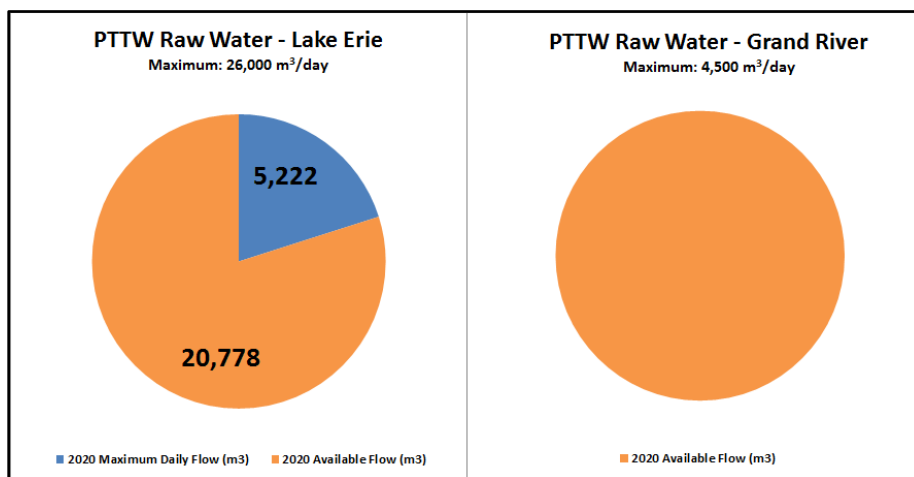

Figure 3: Dunnville Permit to Take Water (PTTW) Flow Comparisons

Potable Water

As required by Schedule 22 of Ontario Regulation 170/03, Table 9, Table 10 and *Figure 3* are intended to provide a summary of potable water supplied by the Dunnville Drinking Water System in 2020.

Table 9: 2020 Dunnville Monthly Potable Water Flow Data

System	Month	Monthly Total m ³	Daily Average m ³	Maximum Day m ³	Maximum Daily Flow Rate L/s
Dunnville Drinking Water System	January	77,700	2,506	3,439	101
	February	73,116	2,521	3,675	103
	March	79,329	2,559	3,764	105
	April	75,573	2,519	4,268	105
	May	93,220	3,007	4,802	152
	June	113,650	3,788	5,845	101
	July	112,492	3,629	5,317	150
	August	109,643	3,537	4,984	157
	September	97,841	3,261	5,254	159
	October	84,385	2,722	3,785	99
	November	80,844	2,695	3,372	106
	December	81,506	2,629	4,087	106

Figure 4 compares the monthly flows over the last five years at the Dunnville Water Treatment Plant. When comparing the average monthly flows for 2019 and 2020, there was a 3.6% increase in potable water supplied to the distribution system.

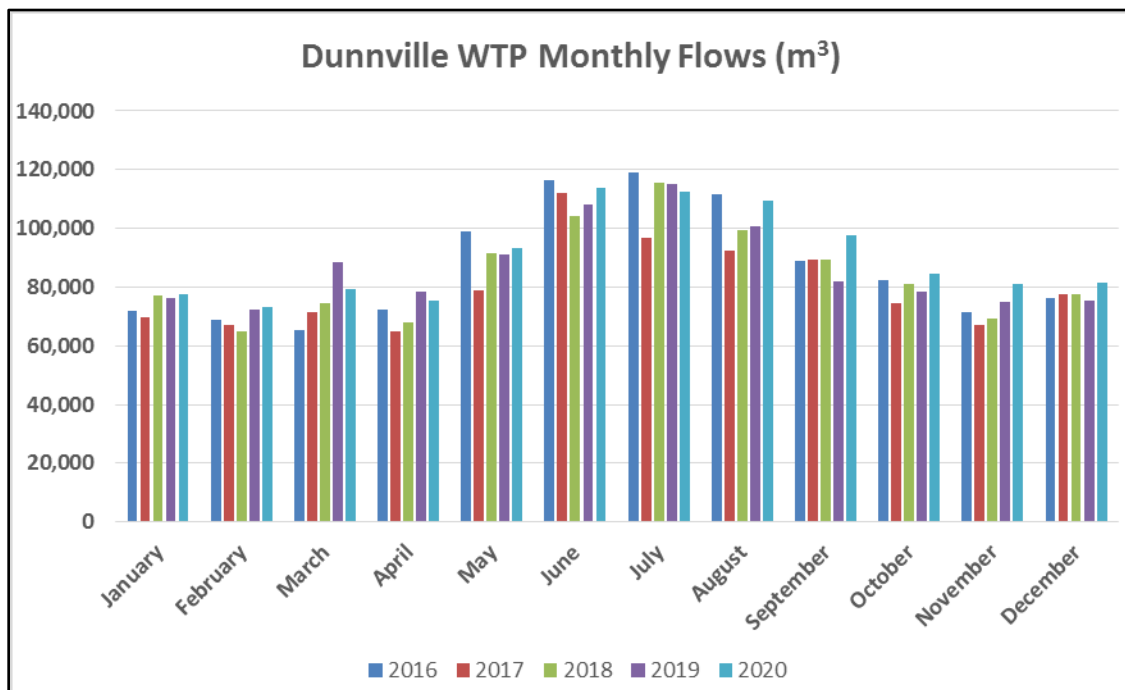

Figure 4: Dunnville Water Treatment Plant Five Year Monthly Potable Flow Comparison

According to the Dunnville Water Treatment Plant's Engineer's Report, the facility has a rated capacity of 14,500 cubic metres per day. When compared against the maximum daily flow for 2020, the Dunnville Water Treatment Plant is operating at approximately 40% of design capacity, however this calculation does not take into account any operational and infrastructure limitations.

Table 10: Comparison of Rated Capacity and 2020 Maximum Flow Rate

System and Municipal Drinking Water License	Rated Capacity	Maximum Daily Flow (m ³ / day)	Percentage of Capacity
Dunnville 066-101	14,500 m ³ /day	5,845 m ³ /day	40.3 %

To ensure the water treatment facility is capable of meeting current and projected demands, Haldimand County staff annually review plant capability and performance and update development allocation accordingly.

REGULATORY COMPLIANCE

Adverse Water Quality Incidents

Regulatory compliance requires reporting adverse water quality incidents to the Ministry of Health (MOH) and the Ministry of the Environment, Conservation and Parks (MECP). In all instances, corrective action is initiated to resolve the issue. A summary of the events and corrective actions is provided in Table 11.

Table 11: 2020 Dunnville Drinking Water System Reported Adverse Events

Incident Date	Parameter	Result	Corrective Action	Date Resolved
July 20, 2020	Total Coliforms	WTP Lab 1 cfu/100 mL	Resampled – upstream, downstream and at the original adverse location.	July 27, 2020
July 23, 2020	Total Coliforms	Dunnville Standpipe 1 cfu/100 mL	Resampled – upstream, downstream and at the original adverse location.	July 27, 2020

Through corrective action sampling for the water treatment plant laboratory adverse, a second adverse sample was reported for the Dunnville standpipe. Additional samples were collected at the site, water treatment plant and within the water distribution system. Follow-up samples all came back negative for the presence of total coliform bacteria.

Annual Drinking Water Inspection

The MECP annually confirms compliance with drinking water legislation by conducting inspections on drinking water systems. All aspects of the drinking water system are reviewed, including treatment equipment, disinfection, training records, and operational data required under the Safe Drinking Water Act, Ontario Regulations 170/03, 169/03 and 128/04. These inspections provide Haldimand County and OCWA an opportunity to review best management practices and work towards continually improving the operation

and management of the drinking water systems. Any issues of regulatory non-compliance are identified and corrective actions issued.

The findings for the 2020 annual drinking water system inspection is included in this report. Below is a summary of the key findings for the inspection:

Dunnville Drinking Water System – Waterworks # 220003555

There were two non-compliance items identified during the 2020 inspection period. The County received a **98.13%** inspection rating from the MECP.

The following issues were identified during the drinking water inspection:

1. A Form 2 document required by the Drinking Water Works Permit was not prepared for a capital project completed at Port Maitland.

Follow-Up: The County has created a procedure for preparing permit forms in March 2020, which was after the Port Maitland project was initiated. This procedure should assist with ensuring all regulatory forms are completed for projects related to the drinking water systems. The County is required to complete and submit a Form 2 and has agreed to complete and submit a Form 3 by April 30, 2021.

2. Lead, total alkalinity and pH were not tested in accordance with Schedule 15.1-5 of Ontario Regulation 170/03.

Follow-Up: The County revised the sample scheduling strategy to ensure that all samples were scheduled in the beginning of the year. The County has also revised the compliance calendar inputs to ensure that reoccurring calendar item end dates are checked for each item after completion. The County has also agreed to conduct lead sampling during the Winter Sampling period and will submit the results to the MECP by April 30, 2021.

During each inspection, the Ministry may provide recommendations and best practices specific to each drinking water system. The MECP provided nine recommendations and observations during the drinking water inspection. Ontario Clean Water Agency have provided the County with an analysis and action plan for the recommendations and the County will work closely with OCWA in developing an implementation strategy for the recommendations.

Haldimand County continues to work closely with regulatory bodies to ensure a continued supply of safe, reliable drinking water to its users. All recommendations have been addressed and communicated to the MECP.

REPORT AVAILABILITY

This report can be viewed online at:

<https://www.haldimandcounty.ca/drinking-water/>

Reports can also be obtained upon request at any Haldimand County Administration Building:



Cayuga Administration Building

53 Thorburn St.

Cayuga, ON

N0A 1E0

For more information on report content, please contact the Haldimand County Environmental Operations Division at:

Email: wwwops@haldimandcounty.on.ca

Telephone: 905-318-5932

Appendix A

Inorganic and Organic Sample Results

Inorganic Parameters:

Parameter	Sample Date	Result Value	Unit of Measure	Exceedance
Antimony	March 9 2020	ND	ug/L	No
Arsenic	March 9 2020	ND	ug/L	No
Barium	March 9 2020	21	ug/L	No
Boron	March 9 2020	ND	ug/L	No
Cadmium	March 9 2020	ND	ug/L	No
Chromium	March 9 2020	ND	ug/L	No
Mercury	March 9 2020	ND	mg/L	No
Nitrite	February 3 2020 May 4 2020 Aug 4 2020 November 2 2020	ND	mg/L	No
Nitrate	February 3 2020 May 4, 2020 Aug 4 2020 November 5 2018	0.399 0.524 0.127 0.202	mg/L	No
Selenium	March 9 2020	ND	ug/L	No
Uranium	March 9 2020	ND	ug/L	No

ND = Not Detectable (below detection limit)

Organic Parameters:

Parameter	Sample Date	Result Value	Unit of Measure	Exceedance
Alachlor	March 9 2020	ND	ug/L	No
Atrazine + Metabolites	March 9 2020	ND	ug/L	No
Azinphos-methyl	March 9 2020	ND	ug/L	No
Benzene	March 9 2020	ND	ug/L	No
Benzo(a)pyrene	March 9 2020	ND	ug/L	No
Bromoxynil	March 9 2020	ND	ug/L	No
Carbaryl	March 9 2020	ND	ug/L	No
Carbofuran	March 9 2020	ND	ug/L	No
Carbon Tetrachloride	March 9 2020	ND	ug/L	No
Chlorpyrifos	March 9 2020	ND	ug/L	No
Diazinon	March 9 2020	ND	ug/L	No
Dicamba	March 9 2020	ND	ug/L	No
1,2-Dichlorobenzene	March 9 2020	ND	ug/L	No
1,4- Dichlorobenzene	March 9 2020	ND	ug/L	No
1,2- Dichloroethane	March 9 2020	ND	ug/L	No
1,1- Dichloroethylene	March 9 2020	ND	ug/L	No
Dichloromethane (Methylene Chloride)	March 9 2020	ND	ug/L	No
2,4- Dichlorophenol	March 9 2020	ND	ug/L	No
2,4- Dichlorophenoxy acetic acid (2,4-D)	March 9 2020	ND	ug/L	No
Diclofop-methyl	March 9 2020	ND	ug/L	No
Dimethoate	March 9 2020	ND	ug/L	No
Diquat	March 9 2020	ND	ug/L	No
Diuron	March 9 2020	ND	ug/L	No
Glyphosate	March 9 2020	ND	ug/L	No
Malathion	March 9 2020	ND	ug/L	No
MCPA	March 9 2020	ND	ug/L	No
Metolachlor	March 9 2020	ND	ug/L	No
Metribuzin	March 9 2020	ND	ug/L	No
Monochlorobenzene (Chlorobenzene)	March 9 2020	ND	ug/L	No
Paraquat	March 9 2020	ND	ug/L	No
Pentachlorophenol	March 9 2020	ND	ug/L	No
Phorate	March 9 2020	ND	ug/L	No
Picloram	March 9 2020	ND	ug/L	No
Prometryne	March 9 2020	ND	ug/L	No
Simazine	March 9 2020	ND	ug/L	No
Terbufos	March 9 2020	ND	ug/L	No
Tetrachloroethylene	March 9 2020	ND	ug/L	No
2,3,4,6- Tetrachlorophenol	March 9 2020	ND	ug/L	No
Total PCBs	March 9 2020	ND	ug/L	No
Triallate	March 9 2020	ND	ug/L	No
Trichloroethylene	March 9 2020	ND	ug/L	No
2,4,6- Trichlorophenol	March 9 2020	ND	ug/L	No
Trifluralin	March 9 2020	ND	ug/L	No
Vinyl Chloride	March 9 2020	ND	Ug/L	No

ND = Not Detectable

¹ Final quarterly Benzo(a)pyrene adverse resample required through Regulation 170 Schedule 24.

Microcystin Sample Results

Parameter	Sample Date	Raw Water Results		Treated Water Results	Unit of Measure	Exceedance
		Lake Erie	Grand River			
Microcystin	June 1, 2020	ND	ND	ND	ug/L	No
	June 8, 2020	ND	ND			
	June 11, 2020			ND		
	June 16, 2020	ND	ND	ND		
	June 22, 2020	ND	ND	ND		
	June 30, 2020	ND	ND	ND		
	July 6, 2020	ND	ND	ND		
	July 13, 2020	ND	ND	ND		
	July 20, 2020	ND	ND	ND		
	July 27, 2020	ND	ND	ND		
	August 4, 2020	ND	ND	ND		
	August 10, 2020	ND	ND	ND		
	August 17, 2020	ND	ND	ND		
	August 24, 2020	ND	ND	ND		
	August 31, 2020	ND	ND	ND		
	Sept. 7, 2020	ND	ND	ND		
	Sept. 14, 2020	ND	ND	ND		
	Sept. 21, 2020	ND	ND	ND		
	Sept. 28, 2020	ND	ND	ND		
	October 5, 2020	ND	ND	ND		
October 12, 2020	ND	ND	ND			
October 19, 2020	ND	ND	ND			
October 26, 2020	ND	ND	ND			

ND = Not Detectable